

THERMOSTATIC STEAM TRAPS AND AIR ELIMINATORS TH13A

DESCRIPTION

The TH13A series thermostatic steam traps and air eliminators are specifically designed for use on process equipment such as kettle cookers, sterilizers, food, chemical and laundry equipment. Their small size makes them ideal for use with a wide variety of this equipment and specially as air eliminator. Connections are female screwed.

MAIN FEATURES

Modulating discharge.
Discharges condensate close to steam temperature.
Thermostats for different sub cooling (5 °C to 30 °C).
Excellent air discharge.
Simple and compact design.
Built-in strainer.

USE: Saturated steam.
AVAILABLE MODELS: TH13A.
SIZES: 1/2".
CONNECTIONS: Female screwed ISO 7/1 Rp (BS21).
INSTALLATION: Vertical installation, angle connection.

PMA – Max. allowable pressure 16 bar
TMA – Max. allowable temperature 260 °C
PMO – Max. operating pressure 13 bar
TMO – Max. operating temperature 200 °C

How to order: i.e. TH13A 1/2" BSP.

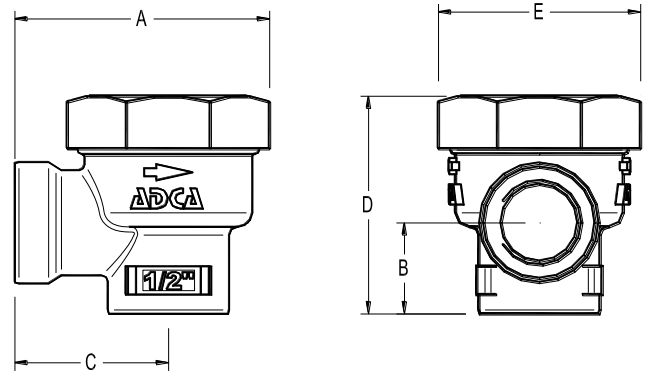
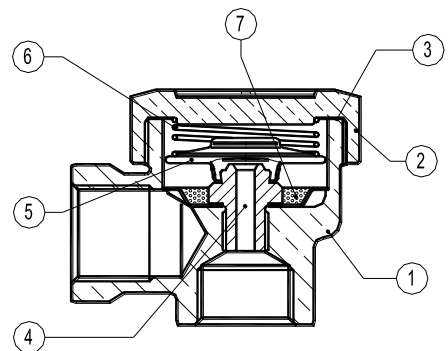

MATERIALS		
POS. Nº	DESIGNATION	MATERIAL
1	Body	Brass EN 12165 / CuZn39Pb2
2	Cover	Brass EN 12165 / CuZn39Pb2
3	* Gasket	Stainless steel / Graphite
4	* Valve seat	AISI 304 / 1.4301
5	* Thermostat	Stainless steel
6	* Spring	AISI 302 / 1.4300
7	* Strainer screen	AISI 304 / 1.4301

* Available spare parts.

DIMENSIONS (mm)						
SIZE	A	B	C	D	E	WGT. (kg)
1/2"	63	22,5	38	54	50	0,5

FLOW RATE CAPACITY (kg/h)													
MODEL	SIZE	DIFFERENTIAL PRESSURE (bar)											
		0,2	0,3	0,5	1	1,5	2	3	4	6	8	10	13
TH13A	1/2"	45	55	70	95	125	135	180	200	270	315	330	360

Capacities shown refer to condensate at 10 °C below saturated steam temperature (standard type S thermostat).

Thermostats for 5 °C (type H) and 30 °C (type L) also available.

Capacities for cold condensate discharge at 20 °C are two to three times greater.